



FINEX SIEVES PVT.LTD.

FINEX SIEVES PVT LTD India's Leading Designer and Manufacturer of Powder Processing Machineries for Grinding, Screening, Mixing, Drying, Crushing, Cleaning, Pelet Making and Material Handling Equipment's and Plants. Established in the year 1981 we are one of the leaders in Designing and Manufacturing of Powder Processing Machineries providing Innovative, Customized products for the process Industries. We supply all over the world with over 2500 successful Installations and are located in Vadodara, Gujarat India's Largest Engineering Industrial Estate. We are having a Land Area of 27,000 sq ft with a built up Area of over 10,000 sq ft.

We also have Demo Machines both in Stainless steel and Mild steel for all the models that we mfg and we offer trials and undertake development work for new application.

FINEX SIEVES PVT. LTD.

606, GIDC, MAKARPURA, VADODARA,
GUJARAT, INDIA-390010.

Ph: - 91-265-2638842, Fax:- 91-265-2311871

M: 91-9376232820

Visit Site: www.finexsieves.com

E-mail: contact@finexsieves.com
fsieves@yahoo.com

FINEX ROTARY DRUM SIFTERS SRX Series For Large Fine powder separations

This is a Rotating Drum Sifter for low Density non abrasive powders specially for screening powders from 10 mesh to 300 mesh. Material is fed in to a Screw Feeder with flat paddles which rotates at a speed from 60 to 120rpm.. The powder is thrown outwards by Centrifugal motion to a Rotating Screen Drum that also rotates in same or opposite direction at a speed from 60 to 100rpm. Often on the Rotating flat paddles brushes or flat wipers of pvc or Teflon are fitted this scrapes along the screen area keeping the screen clean from blinding . Screened powder is discharged below in to a Screw conveyor below from which bagging of powder is done.

Rotary Sifters have screening Drums of various sizes from 1 meter long to 5 meters long .

Applications are for screening Grading powders from 60 mesh to 300mesh. Can handle from 1000kgs/hr to 5000Kgs/hr .

For Chemicals , Foods, Cosmetics, Plastics, Wood flour etc. Fabricated in Carbon steel, Stainlesssteel, Mild Steel.

MODEL	HP	SCREENING AREA	
SR2X	2HP 2Nos	1000mm Long	by 600mm dia
SR3X	3HP 2Nos	1500mm Long	by 750mm dia
SR5X	5HP 3Nos	2000mm Long	by 750mm dia
SR6X	5HP 3nos	3000mm Long	by 750mm dia

POWDER PROCESSING PRODUCT RANGE OF FINEX EQUIPMENTS & PLANTS

<p><u>GRINDING EQUIPMENTS</u> Hammer Mill Pin Mill Micro Mill Plastic Grinding Mills Ultra Fine Mills Air Swept Mills</p>	<p><u>CRUSHING</u> Lump Crushers Lump Breakers Inline Crushers</p>
<p><u>SCREENING EQUIPMENTS</u> Gyratory Separators Vibratory Graders Rotary Sifters Rotary Drum Sifters Cleaning Graders Air Aspirators Destoners Air Classifiers</p>	<p><u>MATERIAL HANDLING SYSTEMS</u> Screw Conveyors Vibratory Feeders Bucket & Belt Conveyors PJ Dust Collectors Rotary Airlock Valves Pneumatic Conveying Systems</p>
<p><u>DRYERS & ROASTERS</u> Pneumatic Dryers Flash Dryers Roasters <u>Continuous</u> FLUID BED PNEUMATIC DRYING PLANTS</p>	<p><u>TURNKEY PLANTS</u> Salt Refinery Spice Plant Air Classification Plants</p> <p><u>BLENDERS & MIXERS</u> Ribbon Blenders Paddle Blenders Drum Mixers</p>

APPLICATIONS

CHEMICLAS	PHARMACEUTICALS	COSMETIC	PLASTICS
Fillers	Insecticides	Detergent	Pigment
Resins	Spices	Ceramics	Fillers
Cement	Food Flour Powder	Lime	Mineral

FINEX- SR 2X MS



FINEX SR 2X MS



FINEX SR 2X SS





FINEX-SR 2X SS

FINEX SR 2X



FINEX
SR 3X STRACH SIFTER



SR 3X ROTARY SIFTER



FINEX -SR 3X



FINEX SR 3X





FINEX-SR 6X





FINEX-SR6X

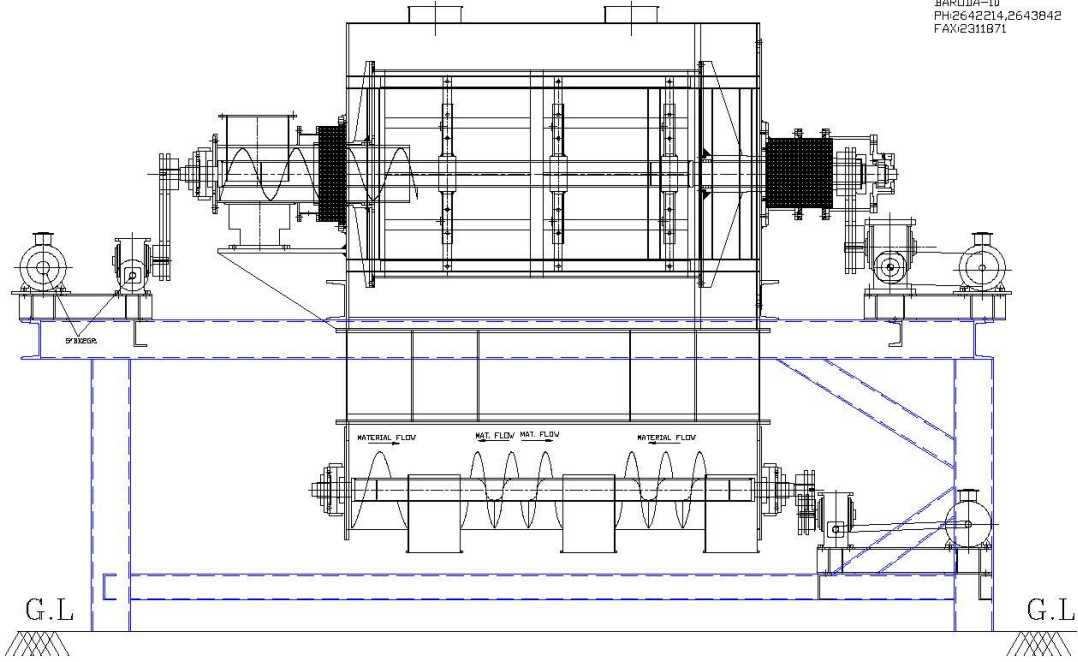

DRG.NO-FSPL/S/R/0003/2006
FINEX SIEVES PVT. LTD.
606 GIDC MAKARPURA,
BARDOLA-10
PH:2642214,2643842
FAX:2311871

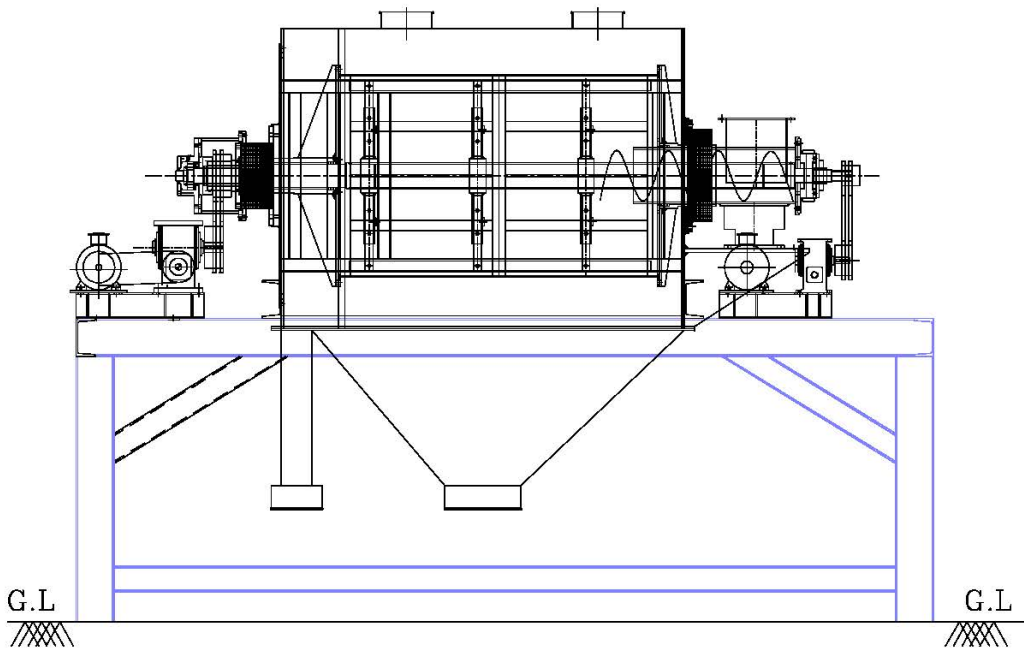



	PART NO.	ALL DIMENSIONS ARE IN MM
		DRN.NO-F/SPL/600TD/010
DRN	SANJAY	FINEX SIEVES PVT.LTD
DATE	26/10/08	
CHD	HARDIK	A1-606 C.I.D.C. BARODA-10
SCALE	1:1	TITLE:-
SR-X		ASSEMBLY (BASKET)